



PROJECT		REF		REV	ITEM CODE	
LOCATION		DATE			PAGE	

SANITARY WARE SPECIFICATION SHEET

Item Descriptions	Stern (Israel) "Smart L" Chrome plated deck mounted long spout sensor faucet in 9V DC Supply with IP67 waterproof battery box	<p>Illustration/ Drawing</p>
Dimensions	L90 x W44 x H142 mm	
Model	Smart LB	
Code Number	235110	
Finish	Chrome Plated	
Supplier	Acme Sanitary Ware Co. Ltd Mr. Eric Wong/ Mr. Don Yuen	
Contact Tel/Fax	(852) 2388-7171 / (852) 2710-8012	
E-mail	acme@acmesanitary.com.hk	
Website	www.acmesanitary.com.hk	

SMART LB Ref # 235110

Touch-free electronic faucet for deck mounted installations. Activated by an infrared sensor. Long spout version. For cold or premixed water. Filters included. Chrome plated body, other finishes available. Includes a low battery indicator. Latching solenoid valve is located above deck inside the product for added vandal protection. Regular faucet installation with simple battery connection. Adjustable setting by remote control: sensor range, security time, delay in, delay out, on-off and reset to factory settings. 24 hour mandatory hygiene flush available upon request.

Application:

Deck-mounted faucets. Combining an elegant minimalist design with anti-vandal features. Easy installation. Long lasting even in the harshest installation sites. Helps washrooms stay clean and saves water. Prevents cross contamination. Ideal for stadiums, train and bus stations and highway rest stops.

Use:

Touch-free electronic faucet. The faucet is automatically activated when the users place their hands in the sensor range and stops when the users remove their hands.

PRODUCT AT A GLANCE

Installation	Lavatory mounted
Power Supply	• 9V external battery box • 9V Transformer
Operating pressure	0.5-8.0 BAR / 7.0-116 PSI For pressure over 8 bar use a pressure reducing valve.
Water flow	6 LPM / 1.58 GPM - SSR PCA stream
Water Saving Options	4 LPM / 1 GPM ; 3 LPM / 0.8 GPM 1.89 LPM / 0.5 GPM ; 1.3 LPM 0.35 GPM - PCA spray
Water temperature	70°C Maximum
Security Time	90 seconds - Adjustable by remote control

ORDERING INFORMATION**OPTIONS**

MODEL	CODE	POWER	ADDITIONAL FEATURES	OPTION	CODE
SMART LB	235110	9V battery	Long Spout 90 mm / 3.54"	Remote control	07100005
				Battery-powered matching soap dispenser	235920
SMART LE	235220	9V Transformer	Long Spout 90 mm / 3.54"	Transformer-powered matching soap dispenser	235900

**Installation:**

Lavatory mounted

**Water supply:**

Cold or premixed water (1 inlet)

**Water temperature:**

Max 70 °C

**Operating pressure:**

0.5 - 8.0 bar

**Power source:**

9V Alkaline battery

**Stern Soap & Water:**

Smart matching soap dispenser



SPARE PARTS LIST

Smart LB
(235110)

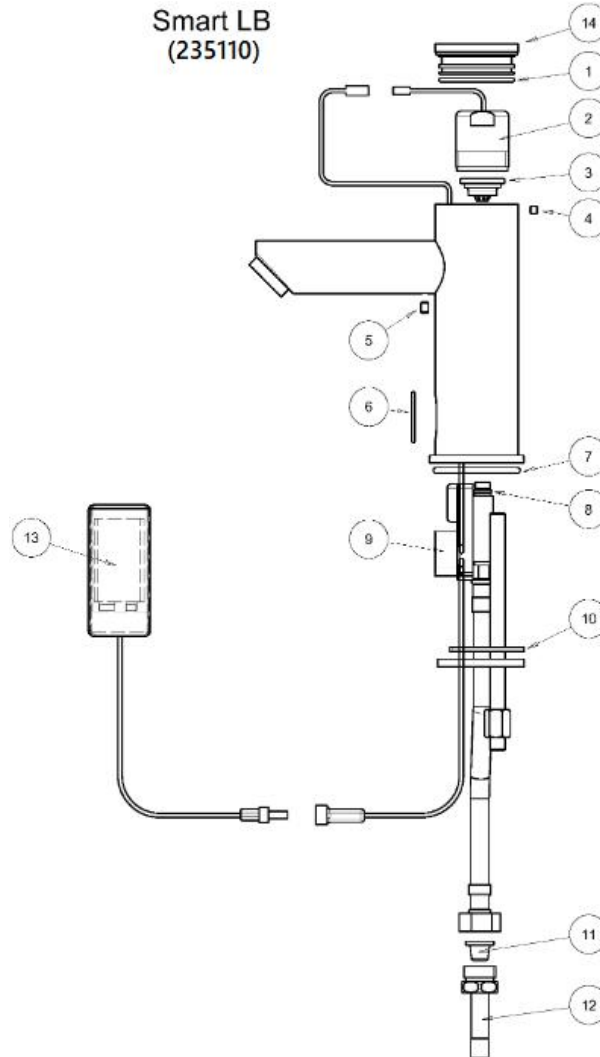

Quantity	Part Number	Description	Cat. No.
-	-	Seals and Screws Kit	07210007
1	1	O-ring	
1	7	O-ring	
1	10	Gasket	
1	4	Screw	
1	5	Screw	
1	6	O-ring	
-	-	Sensor Kit	07220184
1	9	Infra Red Sensor	
1	6	O-ring	
-	-	Filter Adapter Kit	07212001
1	11	Filter	
1	12	Nipple	
-	-	Cover Kit	07270003
1	14	Cover	
1	1	O-ring	
-	-	Solenoid Valve Kit	07230003
1	2	Solenoid valve	
1	3	Diaphragm	
	3	Diaphragm	04500001
	13	Battery box	06530018
	13	IP 67 Battery box	06530019

Note: In order to locate the relevant spare part, please check the corresponding parts and part number in the drawing. Minimum order quantity will be required.

* All information of the above is for the reference only. No prior notice is made if any changes.



INSTALLATION

STEP 1 – PREPARATION FOR MOUNTING THE FAUCET

1 Shut off the water supply.



2 Remove the hexagonal nut, the disk and the gasket. Do not remove the O-ring from the base of the faucet.

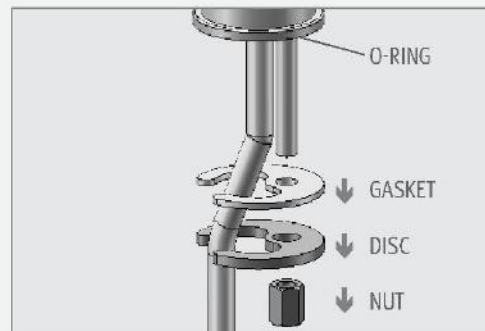

STEP 2 – INSTALLING THE FAUCET

1 Place the faucet with O-ring into the hole in deck or lavatory. Make sure the O-ring is located between the deck or lavatory and the bottom of the faucet.

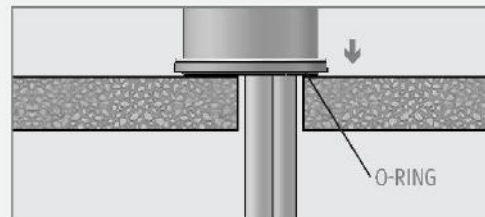

2 Slide the gasket, disk and hexagonal nut over the flexible hose and secure the faucet into place.

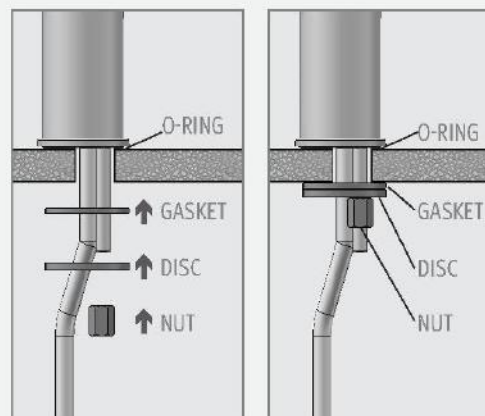



INSTALLATION

STEP 3 – CONNECTING THE WATER SUPPLY

1

Connect the flexible pipe to the water supply.

For models with temperature control connect the red flexible pipe to the hot water supply and the blue flexible pipe to the cold water supply.

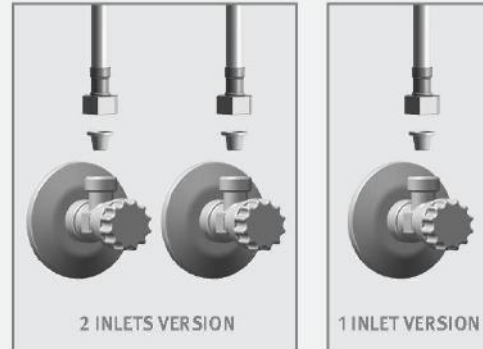

MAKE SURE THAT THE FILTER(S) IS/ARE INSTALLED BETWEEN THE FLEXIBLE PIPE AND THE SHUT OFF VALVE (ANGLE VALVE) (NOT SUPPLIED).

2

Turn on the central water supply and the shut-off valves (angle valves) and check for leaks.

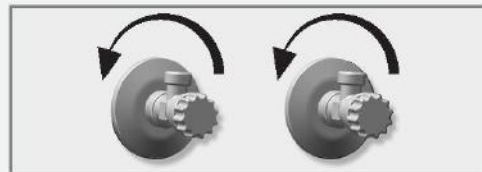



INSTALLATION

STEP 4 – CONNECTING THE POWER SOURCE

BATTERY VERSION

Install the battery box at the wall underneath the sink using the two sided adhesive foam tape. The cable connection must point down. (You can use an optional extension cable in order to assemble the battery box up to 10ft. away from the sink.)

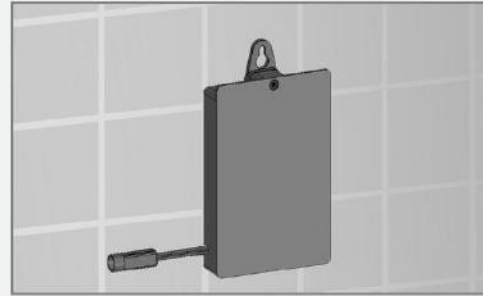

1

TRANSFORMER VERSION

Plug the transformer into the electricity socket and connect the connectors.



2

In order to avoid entering into the adjusting mode, wait 10 seconds before operating the faucet. If the range is unsatisfactory, refer to the section titled “settings adjustment.



ABOUT
10
SECONDS

NOTE: This model includes a special aerator that allows you to adjust the water stream direction on site in order to prevent water splashing if needed. To change the angle of the water stream, simply move the adjustable tilting plate by pressing it smoothly.

ATTENTION! the aerator is tightened to prevent removal by hand.





TROUBLESHOOTING

PROBLEM	INDICATOR	CAUSE	SOLUTION
No water coming out of the faucet:	1. Sensor flashes continuously when user's hands are within the sensor's range.	Low battery.	Replace battery
	2. LED in the sensor does not flash once when user's hands are within the sensor's range.	1. Range is too short.	Increase the range
		2. Range is too long.	Decrease the range
		3. Battery is completely used up	The battery must be replaced.
	3. LED in the sensor flashes once when user's hands are within the sensor's range.	4. Unit is in "Security Mode"*	
		5. Sensor is picking up reflections from the washbasin or another object.	Eliminate cause of reflection.
1. Connectors between the electronic unit and solenoid are disconnected.		Connect the electronic unit connectors to the solenoid.	
		2. Debris or scale in solenoid.	Unscrew solenoid, pull out the plunger and the spring from the solenoid and clean them. Use scale remover material if needed. When replacing the plunger, please make sure that the spring is in vertical position.
3. The central orifice in the diaphragm is plugged or the diaphragm is torn		Clean the orifice or replace diaphragm.	
4. The water supply pressure is higher than 8 bar.	Reduce the supply water pressure.		
Water flow from spout does not stop:	5. The water supply pressure is under 8 bars and yet the pressure in the faucet's body is higher. This situation could be caused by a sudden increase in the water supply pressure that the back check prevents from dropping, even after water supply pressure drops under 8 bars.	Shut off water supply and unscrew one of the flexible pipes in order to reduce the pressure that blocks the product.	
	1. Sensor flashes once when user's hands are within the sensor's range.	Debris or scale in diaphragm	Clean the orifice or replace diaphragm.
Water flow diminished	2. LED in the sensor does not flash once when user's hands are within the sensor's range.	1. Sensor is dirty or covered.**	Clean or eliminate cause of interference.
		2. Sensor is picking up reflections from the washbasin or another object.	Decrease the range or eliminate cause of reflection.
		Filter or aerator is clogged	Remove, clean, re-install

* "Security Mode": If the sensor is covered for more than 90 sec. the faucet will automatically shut off water flow. To return to normal operation remove any blockage.

** In this case, the water flow will stop anyway after 90 seconds because of the security time.